



Series 3000 Installation, Operation and Maintenance

This bulletin should be used by experienced personnel as a guide to the installation and maintenance of the Armstrong SteamEye. Selection or installation of equipment should always be accompanied by competent technical assistance. We encourage you to contact Armstrong or your local Representative if further information is required.

SteamEye Series 3000

Models: RFC 3300, RFM 3300 and RFC 3300R (RFC 3300R not pictured).

Main Components (packaged contents will vary)

Transmitter



Repeater



Receiver



Accessories

- Transformers (Receiver and Repeater)
- Heat Sink (For pressures above 200 psi)
- Pressure switch connection (For Model RFM 3300)
- Ethernet cable
- Insulation jacket (outdoor or extreme conditions).

Transmitter Model RFC 3300

Installation Instructions

1. Verify steam trap model and tag number as shown in Figure 1.
2. Prepare probe thread with sealant or tape.
3. Isolate steam trap station and relieve all steam pressure to trap.
4. Remove probe connection plug on steam trap.
CAUTION: Components may be HOT!
5. Thread transmitter probe into probe connection.
Tighten with wrench on stainless nut only.
CAUTION: Do not tighten using transmitter body.
Torque to NPT standards.
DO NOT OVER TIGHTEN.
6. **SLOWLY** open inlet valve to pressurize steam trap station and verify no leaks are present.
7. **SLOWLY** open outlet valve to commission steam trap station.

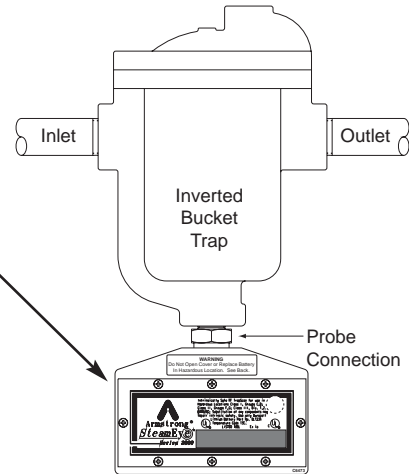

Figure 1. Model URFC 3300 Installation

Transmitter Model RFM 3300

Installation Procedure

1. Verify steam trap model and tag number as shown in Figure 1.
2. Prepare probe thread with sealant or tape.
3. Isolate steam trap station and relieve all steam pressure to trap.
4. Remove probe connection plug on steam trap.
CAUTION: Components may be HOT!
5. Thread transmitter probe into probe connection.
Tighten with wrench on stainless nut only.
CAUTION: Do not tighten using transmitter body.
Torque to NPT standards. DO NOT OVER TIGHTEN.
6. Verify pressure switch has been properly installed up stream of steam trap.
7. Connect cable from transmitter to pressure switch.
 - See Figure 2 for proper pressure switch wiring.**CAUTION: Cable cannot rest on steam pipes or hot surfaces.**
8. **SLOWLY** open inlet valve to pressurize steam trap station and verify no leaks are present.
9. **SLOWLY** open outlet valve to commission steam trap station.

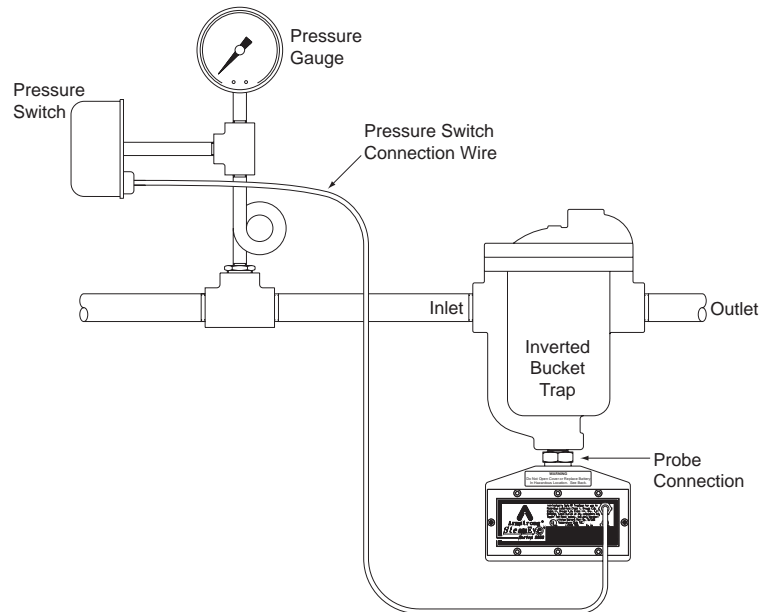

Figure 2. Model RFM 3300 installation with inverted bucket and pressure switch.

Transmitter Model RFC 3300R

Installation Instructions

1. Verify steam trap model and tag number as shown in Figure 1.
2. Prepare probe thread with sealant or tape.
3. Isolate steam trap station and relieve all steam pressure to trap.
4. Remove probe connection plug on steam trap.
CAUTION: Components may be HOT!
5. Thread transmitter probe into probe connection. Tighten with wrench on stainless nut only. **CAUTION: Do not tighten using transmitter body. Torque to NPT standards. DO NOT OVER TIGHTEN.**
6. Locate remote transmitter enclosure where specified by RF survey.
7. Connect cable from transmitter to pressure switch.
• See Figure 3 for proper pressure switch wiring.
CAUTION: Cable cannot rest on steam pipes or hot surfaces.
8. **SLOWLY** open inlet valve to pressurize steam trap station and verify no leaks are present.
9. **SLOWLY** open outlet valve to commission steam trap station.

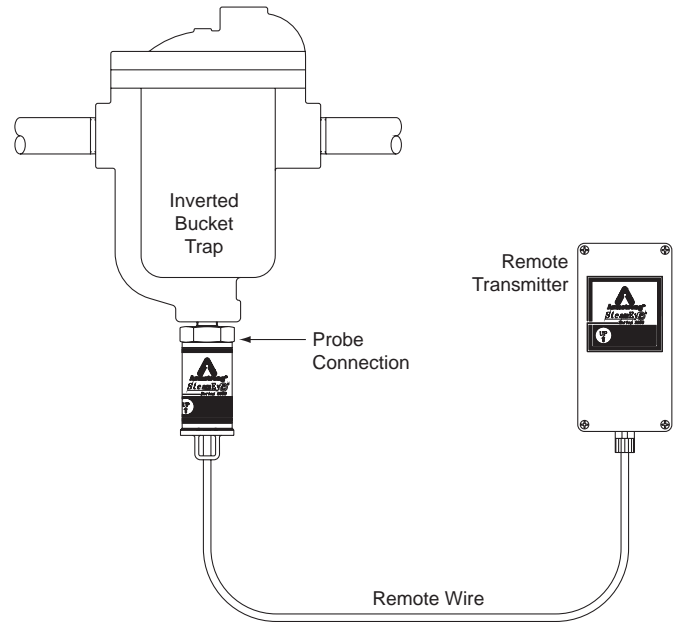

Figure 3. Model RFC 3300R Installation

Transmitter Model RFM 3300R

Installation Instructions

1. Verify steam trap model and tag number as shown in Figure 1.
2. Prepare probe thread with sealant or tape.
3. Isolate steam trap station and relieve all steam pressure to trap.
4. Remove probe connection plug on steam trap.
CAUTION: Components may be HOT!
5. Thread transmitter probe into probe connection. Tighten with wrench on stainless nut only. **CAUTION: Do not tighten using transmitter body. Torque to NPT standards. DO NOT OVER TIGHTEN.**
6. Locate remote transmitter enclosure where specified by RF survey.
7. Connect cable from transmitter to pressure switch.
• See Figure 4 for proper pressure switch wiring.
CAUTION: Cable cannot rest on steam pipes or hot surfaces.
8. Verify pressure switch has been properly installed up stream of steam trap.
9. **SLOWLY** open inlet valve to pressurize steam trap station and verify no leaks are present.
10. **SLOWLY** open outlet valve to commission steam trap station.

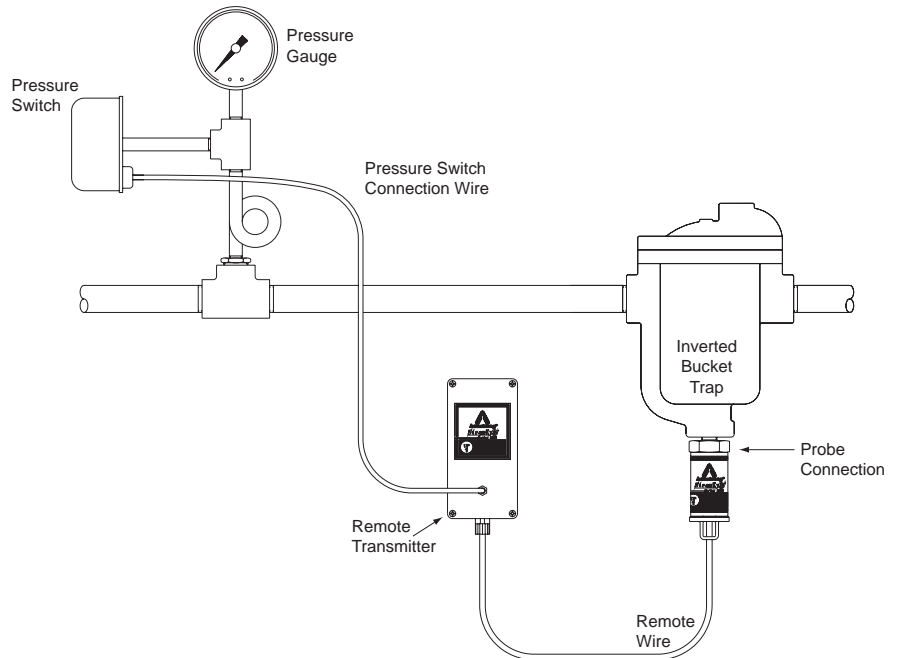

Figure 4. Model RFM 3300 installation with inverted bucket and pressure switch.steamtrap

Series 3000 Receivers

1. Gateway Receiver (WER)
 - a. Preprogrammed by Armstrong from device configuration sheet supplied by the customer.
2. Plug in LAN cable at designated area.
3. Plug in transformer to 120v
4. Logon to web address assigned with user name and password provided.
 - a. Web address supplied by customer. (<http://xxx.xxx.xxx.xxx>)

Series 3000 Gateway Receiver	
Power Requirements	12 VDC - 20 VDC (120 VAC adapter provided)
Power Consumption	100 mA
Receiver Type	Narrow-Band Spread Spectrum
Frequency	902 - 928 MHz
Band Width	100 KHz
Ambient Temperature	30°-125°F indoor/outdoor (0°-52°C)
Cable	Ethernet CAT 5 Cable

5. SteamEye web page
 - a. Critical equipment tab
 - i. List of traps deemed critical by customer
 - ii. Email or txt message sent when critical trap has changed state
 - b. Failed equipment tab
 - i. List of all failed traps
 - c. All equipment tab
 - i. Total trap population monitored by SteamEye
 - d. Configuration tab
 - i. Network Configuration
 - ii. Hardware Profile

The screenshot shows the Armstrong SteamEye web interface in a Mozilla Firefox browser. The page title is "Armstrong SteamEye - Mozilla Firefox". The address bar shows "http://steameye.armstrd.com/StatusHandler". The page features the Armstrong logo and the "SteamEye" brand name. Below the navigation tabs (Critical Equipment, Failed Equipment, All Equipment, Configuration, Logout), there is a section for "All Equipment" with a "Device Type" filter dropdown. A table displays the following data:

Tx#	Fag#	Location	Type	Model No.	Status	Battery	Radio	# State Changes	Last Report	Previous Report - State	Cycle Count
20006	20006	Plant 1 Tests-R-U's North-West Bay Pump Trap #1	Pump Trap w/ Cycle Count	ARM / PUMP TRAP	LOS	OK	2	804	Thu Sep 28 14:05:26 EST 2006	Wed Sep 27 13:46:41 EST 2006 - FL	9925
20007	20007	Lab	Sump Ejector	ARM / Sump Ejector	OK	OK	1	5321	Thu Dec 21 09:36:29 EST 2006	Wed Dec 20 19:32:59 EST 2006 - FL	N/A
20008	20008	Plant 1 Tests-R-U's North-West Bay Pump Trap #2	Pump Trap w/ Cycle Count	ARM / PUMP TRAP	OK	OK	1	1175	Thu Dec 21 09:40:12 EST 2006	Tue Dec 20 15:32:40 EST 2006 - LOS	14325
22222	22222	Lab Test Station	Pump Trap w/ Cycle Count	ARM / 800	OK	OK	4	29	Thu Dec 21 09:40:17 EST 2006	Tue Dec 21 08:57:30 EST 2006 - LC	275
986720	30	Lab CB-4 Drip Trap Tag # 13-2	Steam Trap	ARM / 2011	CD	OK	4	44	Thu Dec 21 09:05:16 EST 2006	Mon Dec 04 15:06:30 EST 2006 - UNK	N/A
986727	986727	Lab	Steam Trap	ARM / FT4000	CD	OK	18	35	Thu Dec 21 09:24:56 EST 2006	Tue Nov 21 09:40:52 EST 2006 - OK	N/A
986763	986763	Lab Test Station	Steam Trap	ARM / 800	LOS	OK	75	37	Sat Dec 16 14:35:43 EST 2006	Fri Dec 15 14:28:05 EST 2006 - LOS	N/A
986786	986786	Lab Test Station	Steam Trap	ARM / 800	CD	OK	68	9	Thu Dec 21 09:34:27 EST 2006	Tue Dec 05 10:01:28 EST 2006 - OK	N/A
986791	25	Tool Room Unit Heater Tag # 6-2	Steam Trap	ARM / TV5812	CD	OK	16	12	Thu Dec 21 09:05:42 EST 2006	Mon Nov 06 16:11:46 EST 2006 - OK	N/A

System Operation and Trouble Shooting

1. BLOWTHRU indicated for all or a large number of traps, check for:
 - a. Steam may be ultra-pure; i.e. reverse osmosis, de-ionized, or some other form of purified water is being used in boiler. In this case jumper in probe should be set at 250.
 - b. Oil or some other non-conductive substance may have leaked into the system. After fixing the leak, isolate the affected traps. The probes should be removed and their tips must be cleaned. The lines to the traps should be blown down to prevent recontamination.
2. If BLOWTHRU is indicated for any particular trap, it may be able to be re-primed.
3. If COLD is indicated for any particular trap, the trap body should be relatively cool. On low pressure or modulating systems it may be necessary to lower temperature alarm set point by moving temperature jumper to a lower temperature set point. If COLD alarm re-occurs check for following:
 - a. Is steam turned on to the trap?
 - i. If a modulating system, use a probe with an external pressure switch or limit switch to eliminate cold alarms when steam shuts off.
 - b. If there is a strainer ahead of the trap it may need cleaning.
 - c. Are the valves upstream and downstream of the trap working properly?
 - d. The trap may not have enough capacity for the condensate load.
 - e. Excessive air in the system can cause "air binding".
 - f. Dirt and scale in the system may have plugged the orifice.
4. Battery status is low. Will show as LOW battery.
 - a. Replace battery with lithium Duracell battery Part No. DL123A (3V) in the transmitter(s). Then press the "reset" button and listen for a beep.
5. Communication status is LOST on a particular trap.
 - a. Make sure transmitter is still installed in the trap.
 - b. Replace battery and press the "reset" button and listen for a beep.
 - c. Administrative time is too short. Lengthen time so that all traps in the system have time to check in.
 - d. Something happened to probe to cause it not to send out signal.
6. Communication status if LOST on multiple traps located in same general area.
 - a. Repeater is not functioning properly
 - b. Repeater not plugged in
 - c. No power to repeater.